

## Pressure Reducing Valves (LFX65B-G)

### ◆ Application:

The Watts LFX65B Pressure Reducing Valves is designed to reduce the static pressure and dynamic pressure in the pipe network system. It's generally used in construction industry, water treatment, etc.

### ◆ Features:

1. Simple structure, light weight;
2. Can maintenance online;
3. Good sealing performance;
4. Long service life, high reliability;
5. Good part interchangeability.



### ◆ Working Principles:

After static pressure and dynamic pressure go into valve, adjusting the spring on the upper part of the valve to make the outlet pressure decreased; After the valve pressure expansion, leaking out pressure through the by-pass pipe to ensure the safety of channel; Built-in filter in the valve can filter out impurities when medium go through.

### ◆ Technical Parameters:

Nominal Diameter:	DN15~DN50
Pressure Adjustable Range:	20psi~80psi (0.138 MPa~0.552MPa)
Standard Pressure:	50psi (0.345 MPa)
Maximum Working Pressure:	2.76MPa
Working Temperature:	0.5℃~82℃
Working Medium:	Water
Test Standard:	GB/T 13927-2008, GB/T 12245-2006

### ◆ Type Instruction:

LFX65B BSP threaded female inlet x BSP female outlet  
 LFX65BDU Double Union –BSP threaded union female inlet and outlet  
 Add the suffix: G - Thread plug at the bottom of the valve

### ◆ Material:

Part	Body	Seat	Strainer	Diaphragm	Disc
Material	Lead Free Bronze	Thermoplastic	Stainless Steel	EPDM	EPDM

### ◆ Installation Dimensions:

Connect Dimensions: GB/T 7307;

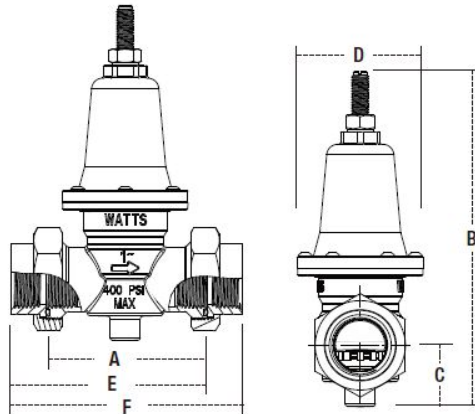

Size(DN)		Dimension										Weight			
		A		B (MAX) STD		C		D (DIA)		E (Threaded)		F (Threaded)			
in.	mm	in.	mm	in.	mm	in.	mm	in.	mm	in.	mm	in.	mm	lbs.	kgs.
1/2	15	3	76.7	5 7/16	137.7	1 5/16	32.8	2 7/16	61.2	3 11/16	93.0	4 5/16	109.2	1.43	0.65
3/4	20	3 1/8	79.8	5 7/16	137.7	1 5/16	32.8	2 7/16	61.2	3 3/4	96.0	4 7/16	112.3	1.52	0.69
1	25	3 9/16	90.4	6 3/16	157.2	1 3/8	34.5	2 3/4	70.6	4 15/16	110.2	5 1/8	130.0	2.22	1.01
1 1/4	32	4 5/16	110.2	6 15/16	176.0	1 9/16	39.40	3 1/4	81.8	5 5/8	142.7	6 7/8	175.3	3.61	1.64
1 1/2	40	5 1/2	140.2	11 3/4	297.9	1 7/8	47.50	4 9/16	115.8	6 13/16	142.7	8 1/16	205.2	9.27	4.20
2	50	5 1/2	140.2	11 3/4	297.9	1 7/8	47.50	4 9/16	115.8	6 13/16	173.5	8 1/8	206.8	9.59	4.35

**Characteristic Curve:**

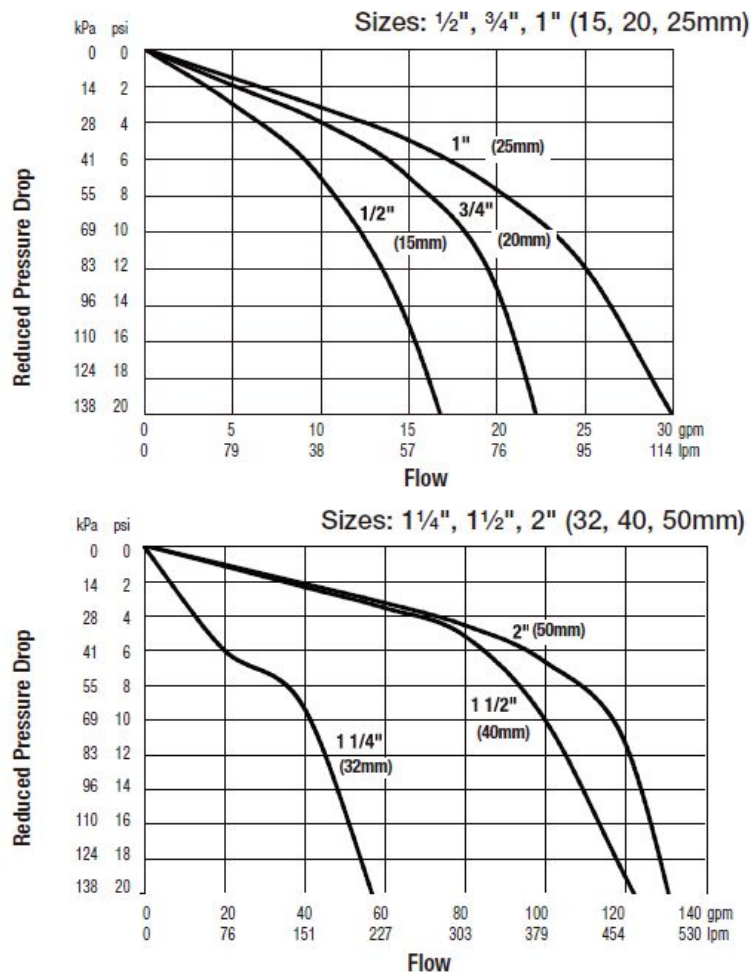

◆ **Typical Application:**

1. Water plant and water source project;
2. Environmental protection;
3. Municipal facilities;
4. Electric power and utilities;
5. Construction industry.

◆ **Installation Instructions:**

- (1) The valve's rated parameters should match the equipment's. Make sure that the valve's rated flow satisfies the actual demand;
- (2) The installer must be trained or experienced so as to operate the installation correctly;
- (3) A thorough check after installation is needed to ensure no errors;
- (4) A thorough cleaning before installation is needed (chemical reagent can be applied if it is necessary) to ensure that there is not any rusting or dirt in the pipe. All the filters must be removed before washing to keep the pipe smoothly open;
- (5) When beginning to wash the system, it is suggested to install the valve on a temporary pipe. After finishing system cleaning, move the valve back and install it on the system's pipe;
- (6) Use threaded connector that meets the standard to connect the valve;
- (7) The direction of flow must accord with the direction of the arrow head on the valve body.